

MULTI TIER TROLLEYS
adjustable position shelves
304 stainless steel

Heavy duty quality, robust construction, good aesthetic style, safety finish is easy to maintain and keep clean. Suitable for any harsh hard working environment where high standard of hygiene is essential.

There are no exposed bolts, brackets or components, all round upstands to each tier, all seamless finish. Designed for kitchens, food service areas, hospitals, laboratories, butchers, abattoirs, bakery, dairy, fishmonger, food processing, veterinary services and any other area where stringent standards are required.

The quality of these trolleys is certified worldwide by:

- NSF** (National Sanitary Foundation)
- ANSI** (American National Standards Institute)
- SSC** (Standards Council of Canada)

Model **SSGT** General purpose trolley is available two, three or four tier - each tier height adjustable. 5" (130 mm) castors are standard, 2 with brake and 2 without brake.

Available with any handle type as shown.

All trolleys are dispatched in easy to handle and store cartons ready for on site assembly.



SSGT324-2N
TWO TIER TROLLEY
NO HANDLES



SSGT324-3S
THREE TIER TROLLEY
STANDARD HANDLES



SSGT324-4H
FOUR TIER TROLLEY
PUSH/PULL HANDLES



MULTI TIER TROLLEYS

adjustable position

Technical Drawing

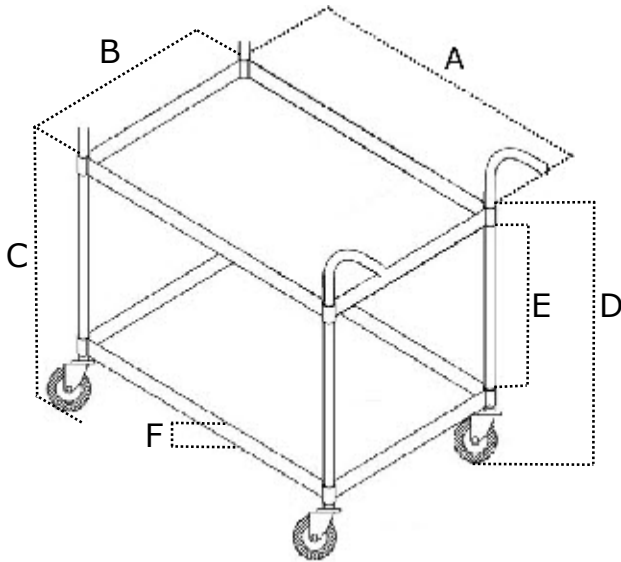

Model numbers for ordering:

Please quote model number when ordering

- SSGT324-2** is a two tier trolley 610 wide, 914 long, 1050 mm high
- SSGT324-3** is a three tier trolley 610 wide, 914 long, 1050 mm high
- SSGT324-4H** is a four tier trolley with push pull handles 610 wide, 914 long, 1050 mm high

Dimensions		millimeters
Nominal length	A	914
Nominal width	B	610
Overall height	C	1050
Shelf height	D	Adjustable
Shelf clearance	E	Adjustable
Tray upstand	F	50

Nominal Packed Dimensions			
	SSGT324-2	SSGT324-3	SSGT324-4
970 Long 680 Wide	140 Deep	210 Deep	280 Deep
Approximate Packed Weight			
	22 kg	30 kg	37 kg
Optional Extras			
Standard Handles	Add S to model number e.g. SSGT324-4S		
Push Pull Handles	Add H to model number e.g. SSGT324-4H		
No Handles	Add N to model number e.g. SSGT324-4N		

Construction	
Trays	304 Stainless steel 1.2 mm (18 gauge)
Legs	304 Stainless steel tube 25 mm o/d
Castors	130 mm Neoprene - 2 braked and 2 plain



Specifications subject to continuous improvement program



AMERICAN CATERING EQUIPMENT (UK) LIMITED
 5 CHANTRY COURT
 SOVEREIGN WAY
 CHESTER WEST
 CHESTER CH1 4QN
 UNITED KINGDOM

TEL: + 44 (0) 1244 381281
 FAX: + 44 (0) 1244 381700
 OFFICE: FSE@ACE-UK.COM
 PARTS: PARTS@ACE-UK.COM
 WEBSITE: WWW.ACE-UK.COM

